

# Behavior of railroad bearing due to temperature and load using LISA FEA

**Aco Wahyudi Efendi**

<sup>1</sup>Universitas Tridharma,  
Jl. A.W. Syahrani No.7, Batu Ampar, Balikpapan Utara, Balikpapan, 76126, Indonesia

---

## Article Info

### Article history:

Received 15 January 2022  
Revised 30 January 2022  
Accepted 11 February 2022

### Keywords:

Bearing  
Railroad  
Stress  
LISA  
FEA

## ABSTRACT

A very important element of railway is the rail bearing, different types of rail bearings that we know in Indonesia are wooden rail bearings, concrete rail bearings. In this study, the stress behavior that occurs in the two types of railway bearings due to the load and the occurring temperature effect is to be checked. It was found that the stress occurring in bearings with different materials, namely concrete and wood, when the The nominal stress can be seen on the concrete bearing is 11.87 N/mm<sup>2</sup>, on the wooden material the bearing load is 10.41 N/mm<sup>2</sup>. As for the temperature effect, it looks similar to the temperature of 80 °C for each material, but it can be seen that the temperature effect spreads from the surface due to the friction between the railroad tracks and the railroad wheels.

### \*Corresponding Author:

Aco Wahyudi Efendi  
Department of Civil Engineering, Universitas Tridharma Balikpapan  
Sepinggian Pratama J7/9 Balikpapan Kalimantan Timur 76115, Indonesia  
Email: aw.efendi2018@gmail.com

## 1. INTRODUCTION

A train is a vehicle in the form of a vehicle with propulsion power that travels alone or in combination with other vehicles that travel on rails [1]. Trains usually consist of a locomotive propelled by the power of a human, called a driver, with the help of an engine, and a number of trains or wagons as a place to carry goods and/or passengers. Series of trains or wagons are relatively large, so they can load passengers or goods in large quantities. Due to being an efficient public transport, some countries try to make the most of it. As the main means of land transport both within cities and between cities and between countries.

Rail transport is the provision of transport services by rail for the transport of goods and passengers. The train ensures the safety, comfort, and safety of passengers [2]. Railroad axles are one of the key components of train[3]. They should retain the weight of the body and transfer it to the wheels [4]. In addition, railroad axles are relevant to the safety of passengers while traveling. Railroad axles are always supported by several bearings. Therefore, in this case, the railroad axles and supported bearings are important. The other important element is the rail bearing, different types of rail bearings that we know in Indonesia are wooden rail bearings, concrete rail bearings, steel rail bearings and concrete slab rail bearings. In railway vehicles, rolling element bearing are used for axle journals, shafts of main motors, running gears, and others [5]. Bearings also used to transmit rotary motion and to support radial and thrust loads[6]. During operation, it is important to regularly check bearing condition by performing baseline condition monitoring measurements [7][8]. A

number of condition monitoring techniques can be used to examine a range of check bearing condition[9], including vibration analysis[10]–[12], acoustic analysis[13]–[16], thermometer monitoring[17], wear debris analysis[18], motor current signature[19]–[23].

Monitoring of the bearing conditions of railroad axle studies is a recent topic [24]. The previous study on railroad bearing by Tarawneh et al[25], Cole et al[26], and Cuanang et al[27]. Tarawneh et al conducted an experiment to obtain temperature history at several locations on a stationary bearing subjected to a heat source embedded in two rollers. Experimental results are compared with zero and first order thermal models to estimate the overall heat transfer of the bearings. The results presented here can be used to explain some of the mechanisms that cause excess heat in tapered roller bearings. While Cuanang et al performs current bearing condition monitoring including using a non-contact infrared sensor to detect abnormal bearing temperatures as they pass through the detector.

In this study, the stress behavior that occurs in the four types of railway bearings due to the load and the occurring temperature effect is to be checked.

## 2. RESEARCH METHOD

In this study, the author will model the Railroad bearings using the LISA FEA V.8 finite element analysis software to perform a model analysis on the 2 Railroad bearing materials. The size of the railway bearing refers to the Regulation of the Minister of Transport of the Republic of Indonesia No. PN. 60 of 2012 on the technical requirements for the railway line. A typical 1435mm rail width railway is used and installed in a standardized cant position [28]

According to Figure 1 with regard to the position of the railway bearing and the rail construction is made as good as possible to be able to withstand high loads or the term AXLE LOAD of the train series running on it, so that this steel road can last long and the train series can run fast, safe and comfortable.

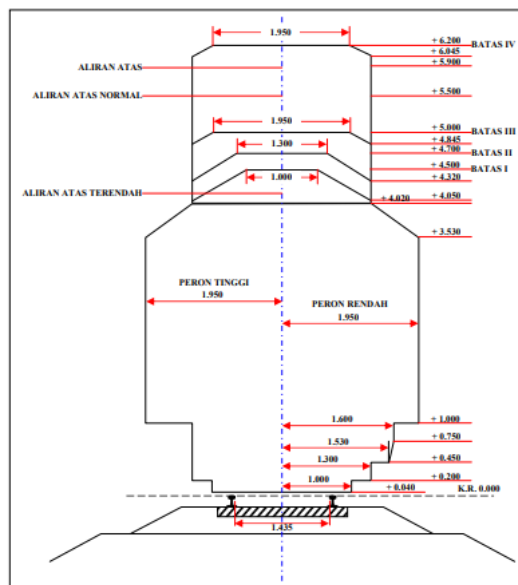

**Figure 1.** The position of laying the railroad tracks on the bearings

### 2.1. Bearing Railroad

The bearing serves to transfer the rail load and the weight of the railroad structure to the ballast, maintaining the width of the railroad and stability to the outside of the rail. Bearings can be made of wood, steel/iron or concrete. The choice of storage type is based on the variety and field conditions, as well as availability. The specifications for each bearing type must refer to the applicable technical requirements.

Camps consist of concrete camps, wooden camps and iron camps. Bearings must meet the following requirements:

- A. Concrete bearings are prestressed structures:
  1. For a rail width of 1067 mm with a characteristic concrete compressive strength of at least 500 kg/cm<sup>2</sup> and the quality of the prestressed steel with a minimum tensile strength of 16.876 kg/cm<sup>2</sup> (1.655 MPa). Concrete bearings must be able to absorb a minimum moment of +1500 kg m at the rail seat and -930 kgm in the center of the bearing.

2. For a rail width of 1435 mm with a characteristic concrete compressive strength of at least 600 kg/cm<sup>2</sup>, and the quality of the prestressed steel with a minimum tensile strength of 16.876 kg/cm<sup>2</sup> (1.655 MPa). Depending on the design of the axle load and speed, concrete bearings must be able to absorb the minimum moments.

**B. Wood Bearings**

Load-bearing wood must meet the requirements for quality wood A class 1 with a minimum modulus of elasticity (E) of 125,000 kg/cm<sup>2</sup>. Must be able to withstand a maximum moment of 800 kg-m, absolute deflection must not be less than 46 kg/cm<sup>2</sup>. Minimum wood density = 0.9, maximum moisture content of 15%, free of knots, cracks must not be longer than 230 mm from the end of the wood.

**C. Steel Bearing**

Steel bearings must contain 900A grade carbon manganese steel in the middle of the bearing and at the bottom of the rail, which can withstand a maximum moment of 650 kg m and a tensile stress of 88-103 kg m. Elongation A1 > 10%.



**Figure 2.** Different kinds of railroad bearing

**2.2. Rail**

A. Rails must meet the following requirements:

- a. At least 10% elongation.
- b. Tensile strength (tensile strength) at least 1175 N/mm<sup>2</sup>;
- c. The hardness of the rail head should not be less than 320 BHN.

The rail cross-section must correspond to the rail dimensions according to the table and the following figure:

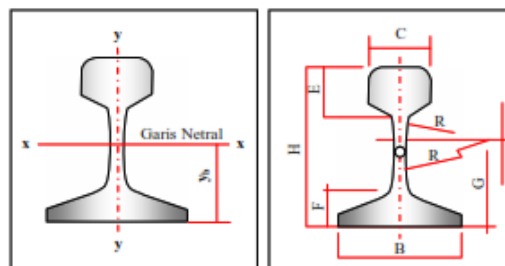

**Figure 3.** Rail dimensions

**Table 1 - Rail Section Dimensions**

Geometric size	Rail Type			
	R 42	R 50	R 54	R 60
H (mm)	138.00	153.00	159.00	172.00
B (mm)	110.00	127.00	140.00	150.00
C (mm)	68.50	65.00	70.00	74.30
D (mm)	13.50	15.00	16.00	16.50
E (mm)	40.50	49.00	49.40	51.00
F (mm)	23.50	30.00	30.20	31.50
G (mm)	72.00	76.00	74.79	80.95
R (mm)	320.00	500.00	508.00	120.00
A (cm <sup>2</sup> )	54.26	64.20	69.34	76.86
W (kg/m)	42.59	50.40	54.43	60.34
I <sub>x</sub> (cm <sup>4</sup> )	1,369.00	1,960.00	2,346.00	3,055.00
Y <sub>b</sub> (mm)	68.50	71.60	76.20	80.95

The explanation of the symbol above is

A = cross-sectional area

W = rail weight per meter

I<sub>x</sub> = moment of inertia about the x-axis

Y<sub>b</sub> = the distance from the bottom of the rail to the neutral line

Different types of rail rod affect several things, including the maximum pressure (axle load) the rail can take when the train passes, and the allowable speed of the train as it passes the rail. The larger the “R”, the larger the axle load that the rail can bear, and the train running over it can run stably and safely at high speeds. [2]

### 2.3 Railway components

After the foundation layer is completed as the foundation of the railway, the next stage is to build the railway tracks. Please note that each component affects the quality of the railway itself. Figure 4 below shows a railroad schematic and its components.

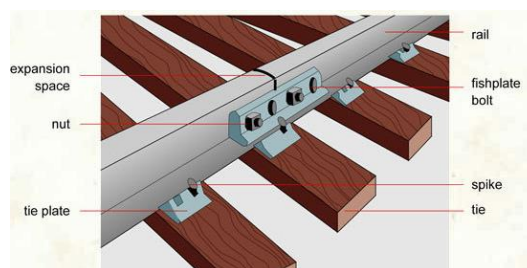

**Figure 4.** Railroad track components (source: [www.infovisual.info](http://www.infovisual.info))

### 2.4 Finite element method (FEM)

The finite element method (FEM) is a numerical method for solving technical analysis problems. The finite element method combines several mathematical concepts to generate equations of a linear or nonlinear system. The number of equations generated is usually very large, reaching more than 20,000 equations. Therefore, this method is of little practical value unless a suitable computer is used[29].

When a structure is subjected to forces such as stress, pressure, temperature, flow rate, and heat, the result is strain (deformation), stress, temperature, pressure, and flow rate. The nature of the distribution of the resulting action (deformation) on a body depends on the properties of the force and stress system itself. In the finite element method, you can find the distribution of this effect, expressed as displacement.

The finite element method uses an element discretization approach to solve the problem of finding displacements of vertices/connections/lattices and structural forces. Discrete element equations are related to the matrix method for structural analysis and the results obtained are identical to those of classical analysis for structures. The discretization can be done with one-dimensional elements (line elements), two-dimensional (plane elements) or three-dimensional (volume/continuum elements). This approach uses a continuum element to determine a solution that is closer to the truth [30].

## 2.5. LISA

LISA, a popular finite element analysis application, was used to estimate the temperature rise for three different models of heat exchangers. The three types of models are, in order of their simplicity and ease of construction, the line element model, the shell model, and the solid model.

For line elements, LISA provides a menu of commonly used structural shapes, users only need to add the element's dimensions in one dialog box and thermal conductivity in another dialog box. For line element models only, the convection coefficient of the baseplate surface needs to be determined as half the value used elsewhere since we cannot exclude convection from assembling the baseplate surface with the face selection tool. It's just a matter of common sense.

For the other two models, it's easy to exclude the mounting surface from convection - we just don't select that surface. An internal heat generator is used in each case, and the volume of the entire floor slab is assumed to be the heat source. Care should be taken when applying boundary conditions to a line element model. LISA selects all surfaces of the line elements when the "Area" selection is made (i.e. both "ends" of the line and all "sides" of the line) [31].

## 3. RESULTS AND DISCUSSION

In this study, the bearing railway state is restricted to conditions with a rail width of 1435mm and a maximum height of 150mm, with a typical scheme over railways under can't conditions as shown in Figures 1 and 10.

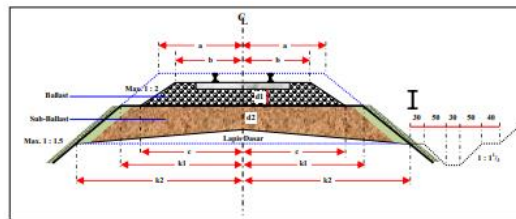

**Figure 10.** Cross Section of Railroad in Straight Section (Railway Width 1435 mm)

For a typical rail width as shown in Figure 11.

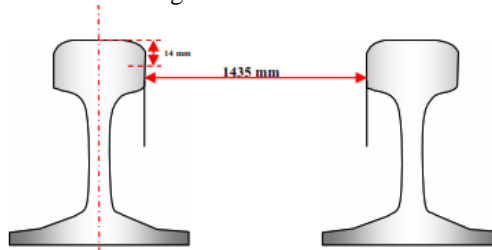

**Figure 11.** Railway width 1435 mm

The road class is limited to the rail class Type I with a load capacity  $> 20 \cdot 10^6$  tons/year, a speed of 160 km/h, the maximum P-load of the axle is 22.5 tons when using the rail type, R.60 with the bearing type like figure 12, For the 3 types of analysis used steel, concrete and wood, the distance between the bearing axes is 60 cm.

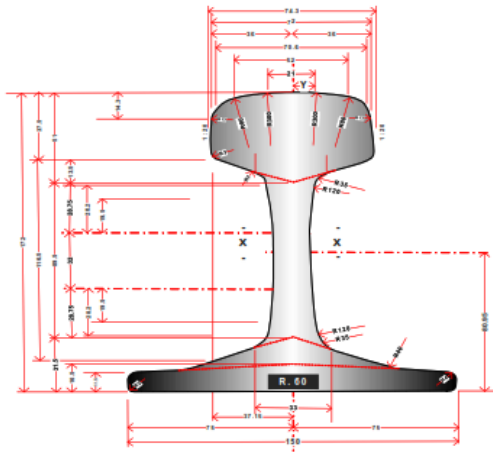

**Figure 12.** Rail section size R.60

### 3.1. Stress Behavior of bearing and railway with LISA

Dimensions of the concrete bearing used, the bearing length with the above axle load is 2,740 mm 22.5 tons and with a maximum width of 330 mm with a height under the rail mount of 220 mm while for steel, timber stocks are modeled with the same dimensions as concrete stocks. The load used is the largest axial load with 22.7 tons which works to rub the top surface of the rail with a width of 74.2 mm so that the load is evenly divided into 3032.345013 N/mm.

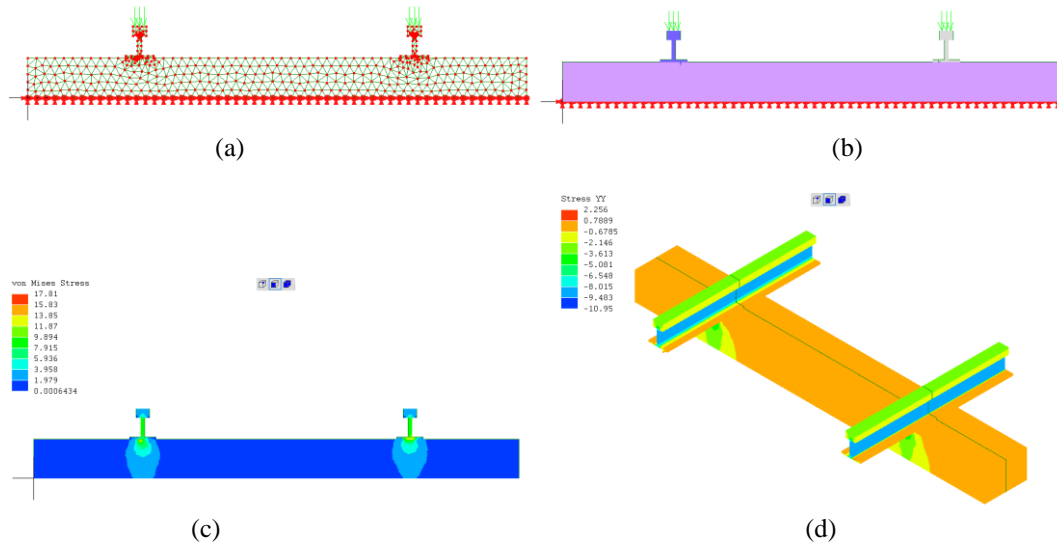

**Figure 13.** Stress Behaviour of Concrete Bearing

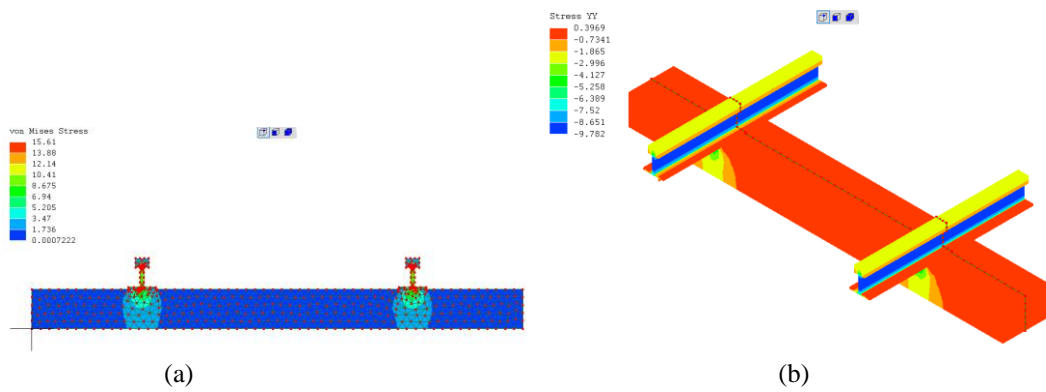

**Figure 14.** Stress Behaviour of Wood Bearing

From Figure 13(c)(d) and Figure 14 show the same loading pattern and different rail support materials, for the rail itself using a steel profile as shown in Figure 12 while the rail supports are made in 2 models namely concrete and wood.

It can be seen that a large stress occurs at the top of the surface where friction occurs between the railway wheels and the rail, the concrete material occurs on the surface of the rail and is  $17.81\text{N/mm}^2$ , while the stress occurring in the wood material occurs is  $15.61\text{ N/mm}^2$ , while the part of the bearing directly interacting with the rail is subject to alternating loads, with the nominal stress on the concrete bearing being  $11.87\text{ N/mm}^2$ , on the wooden material the bearing load is  $10.41\text{ N/mm}^2$ .

### 3.1. Temperature behavior of bearing and railway with LISA

After analyzing the workload, the researcher carried out railway modeling to find out the behavior of the railway rails due to the temperature that occurred where the temperature was measured at 470 degrees, due to the large surface temperature and below the friction stress caused by the contact surface, which of course the nature of the load can affect mechanical properties of the material if the generated temperature is high enough (more than  $250\text{ }^\circ\text{C}$ ). This too can contribute to accelerating the failure of the rail material. With large contact surfaces, temperatures of approx.  $470\text{ }^\circ\text{C}$  can be reached. The underground temperature, which can affect the mechanical properties of the material, can reach a depth of about 30 m with a temperature of about  $260\text{ }^\circ\text{C}$  [32] [33]

Regarding the modelling, 3 models were made according to the original modeling due to loads applied with different bearing materials namely concrete, wood and steel. Modeling as in Figure 15.

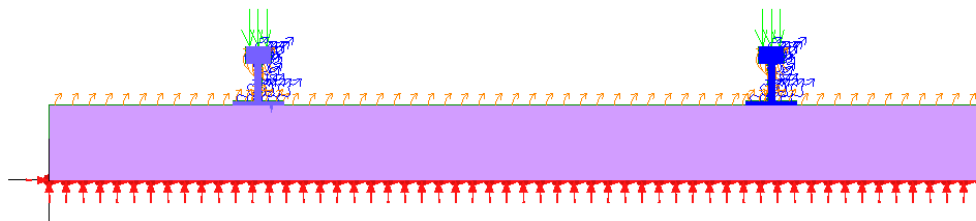

Figure 15. Modeling of bearing with temperature

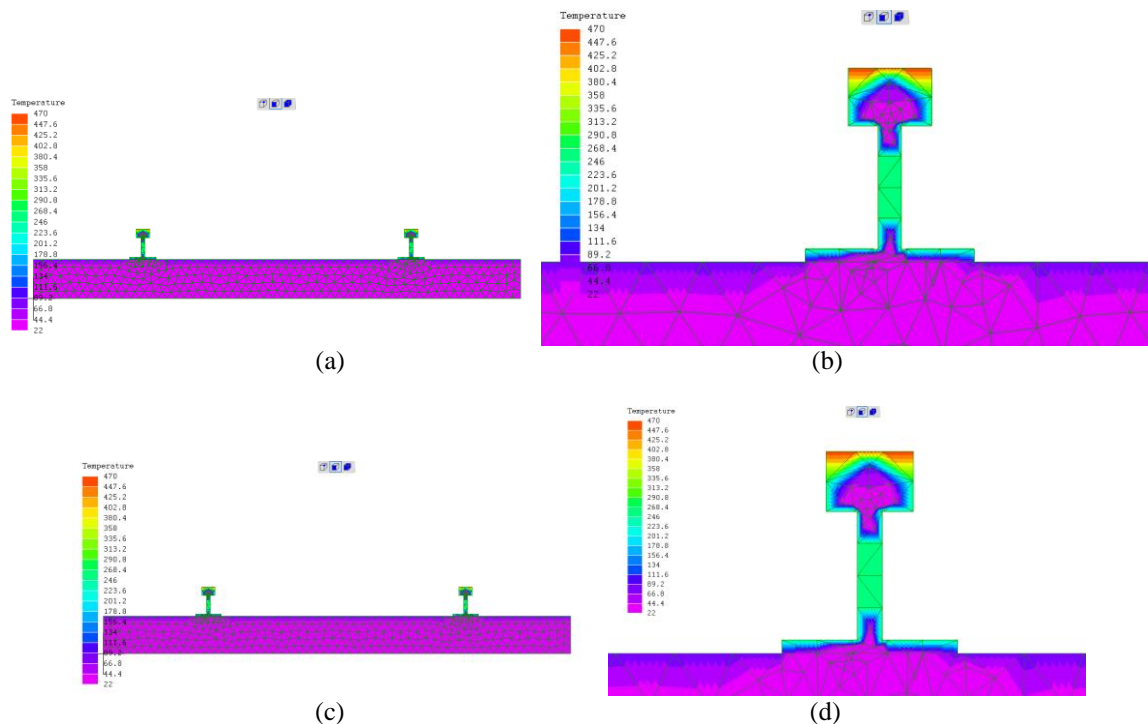

Figure 16. Temperature behaviour of bearing (a)(b) Concrete Bearing (c)(d) Wood Bearing

Based on the results of the analysis of the behavior of the railway with 2 types of material from the bearings used and considering the temperature due to the friction of the train wheels with the railway tracks, it can be seen that the scattering that occurs due to the prevailing temperature on the rail surface is very large and spreads to rail body and rail section steel while railroad ties are affected by the temperature spread and additional temperatures due to direct sunlight and the temperature around the railroad tracks. As shown in Figure 16. The temperature distribution corresponds to the indicated temperature based on previous investigations into the friction of railway rails with railway wheels, which generates an extreme temperature of 470°C and is reflected on the tread body at 260°C and on the tread at 80°C.

#### 4. CONCLUSION

Investigations using the Finite Element Analysis (FEA) modeling method with the LISA V.8 software, it was found that the stress occurring in bearings with different materials, namely concrete and wood, when the nominal stress can be seen on the concrete bearing is 11.87 N/mm<sup>2</sup>, on the wooden material the bearing load is 10.41 N/mm<sup>2</sup>. As for the temperature effect, it looks similar to the temperature of 80 °C for each material, but it can be seen that the temperature effect spreads from the surface due to the friction between the railroad tracks and the railroad wheels.

#### ACKNOWLEDGEMENTS

Author would like to thank all parties who contributed to this research from data collection, processing, and analysis. Any suggestion which will contribute for improving this paper is welcomed.

#### REFERENCES

- [1] AskOxford.com, "Definition of Train (noun) in Compact OED," *AskOxford.com*, 2005. [https://web.archive.org/web/20050526072449/http://www.askoxford.com/concise\\_oed/train?view=uk](https://web.archive.org/web/20050526072449/http://www.askoxford.com/concise_oed/train?view=uk)
- [2] A. Salim, *Manajemen Transportasi*. Jakarta: Radja Grafindo, 2004.
- [3] B. Asngali, A. Susanto, M. F. Subkhan, I. Martinez, K. Yamada, and F. Majedi, "Static Analysis of Railway Axle using Finite Element Method and Monitoring of Railway Bearing Based on Vibration Analysis," *J. Phys. Conf. Ser.*, vol. 1845, no. 1, 2021, doi: 10.1088/1742-6596/1845/1/012037.
- [4] F. Dikmen, M. Bayraktar, and R. Guclu, "Determination of critical section of wagon axle by considering dynamic and safety factors," *Alexandria Eng. J.*, vol. 58, no. 2, pp. 611–624, 2019, doi: <https://doi.org/10.1016/j.aej.2019.05.010>.
- [5] T. Nagatomo and D. G. Toth, "Investigation of the bearing damage progression starting from cone creep of a railroad axle journal bearing," *Q. Rep. RTRI (railw. Tech. Res. Institute)*, vol. 47, no. 3, pp. 119–124, 2006, doi: 10.2219/rtriqr.47.119.
- [6] R. Guo, G. Yang, Z. Li, Z. Liu, and Y. Wei, "Statistical analysis on rolling contact fatigue in railroad axle bearing steel," *Fatigue Fract. Eng. Mater. Struct.*, vol. 42, no. 3, pp. 651–663, 2019, doi: 10.1111/ffe.12940.
- [7] N. S. P. Luna and D. Galar, *TECHNICAL REPORT Inspection and Analysis of the Functioning of the Inspection and Analysis Bearings Used of on the Functioning Bearings*. Lulea University of Technology, 2014.
- [8] C. Malla and I. Panigrahi, "Review of Condition Monitoring of Rolling Element Bearing Using Vibration Analysis and Other Techniques," *J. Vib. Eng. Technol.*, vol. 7, no. 4, pp. 407–414, 2019, doi: 10.1007/s42417-019-00119-y.
- [9] A. Lamari, "Rolling stock bearing condition monitoring systems," no. October, p. 116, 2008, [Online]. Available: <http://eprints.usq.edu.au/5886>
- [10] J. Mathew and R. J. Alfredson, "The condition monitoring of rolling element bearings using vibration analysis," *J. Vib. Acoust. Trans. ASME*, vol. 106, no. 3, pp. 447–453, 1984, doi: 10.1115/1.3269216.
- [11] S. Janjarasjitt, H. Ocak, and K. A. Loparo, "Bearing condition diagnosis and prognosis using applied nonlinear dynamical analysis of machine vibration signal," *J. Sound Vib.*, vol. 317, no. 1–2, pp. 112–126, 2008, doi: 10.1016/j.jsv.2008.02.051.
- [12] G. Y. Luo, D. Osypiw, and M. Irle, "On-line vibration analysis with fast continuous wavelet algorithm for condition monitoring of bearing," *JVC/Journal Vib. Control*, vol. 9, no. 8, pp. 931–947, 2003, doi: 10.1177/10775463030098002.
- [13] C. James Li and S. Y. Li, "Acoustic emission analysis for bearing condition monitoring," *Wear*, vol. 185, no. 1–2, pp. 67–74, 1995, doi: 10.1016/0043-1648(95)06591-1.
- [14] H. Sadeh, A. N. Mehdi, and A. Mehdi, "Classification of acoustic emission signals generated from



- journal bearing at different lubrication conditions based on wavelet analysis in combination with artificial neural network and genetic algorithm,” *Tribol. Int.*, vol. 95, pp. 426–434, 2016, doi: 10.1016/j.triboint.2015.11.045.
- [15] S. Kumar, D. Goyal, and S. S. Dhama, “Statistical and frequency analysis of acoustic signals for condition monitoring of ball bearing,” in *7th International Conference of Materials Processing and Characterization, ICMPC 2017*, 2018, vol. 5, no. 2, pp. 5186–5194. doi: 10.1016/j.matpr.2017.12.100.
- [16] M. Entezami *et al.*, “Acoustic analysis techniques for condition monitoring of roller bearings,” in *6th IET Conference on Railway Condition Monitoring, RCM 2014*, 2014, vol. 2014, no. CP631. doi: 10.1049/cp.2014.1012.
- [17] A. Choudhary, T. Mian, S. Fatima, and B. K. Panigrahi, “Passive Thermography Based Bearing Fault Diagnosis using Transfer Learning with Varying Working Conditions,” *IEEE Sens. J.*, 2022, doi: 10.1109/JSEN.2022.3164430.
- [18] B. T. Kuhnell and J. S. Stecki, “CORRELATION OF VIBRATION, WEAR DEBRIS ANALYSIS AND OIL ANALYSIS IN ROLLING ELEMENT BEARING CONDITION MONITORING.,” *Maint. Manag. Int.*, vol. 5, no. 2, pp. 105–115, 1985, [Online]. Available: <https://www.scopus.com/inward/record.uri?eid=2-s2.0-0022062570&partnerID=40&md5=aedd0e65835408dbabf1be8f596688>
- [19] T. G. Habetler, R. G. Harley, R. M. Tallam, S.-B. Lee, R. Obaid, and J. Stack, “Complete current-based induction motor condition monitoring: Stator, rotor, bearings, and load,” in *8th IEEE International Power Electronics Congress, CIEP 2002*, 2002, vol. 2002-January, pp. 3–8. doi: 10.1109/CIEP.2002.1216628.
- [20] L. Frosini, E. Bassi, A. Fazzi, and C. Gazzaniga, “Use of the stator current for condition monitoring of bearings in induction motors,” 2008. doi: 10.1109/ICELMACH.2008.4799991.
- [21] F. J. T. E. Ferreira, J. P. Trovão, and A. T. De Almeida, “Motor bearings and insulation system condition diagnosis by means of common-mode currents and shaft-ground voltage correlation,” 2008. doi: 10.1109/ICELMACH.2008.4800051.
- [22] Z. Yang, “Automatic Condition Monitoring of Industrial Rolling-Element Bearings Using Motor’s Vibration and Current Analysis,” *Shock Vib.*, vol. 2015, 2015, doi: 10.1155/2015/486159.
- [23] T. Ciszewski, A. Dzwonkowski, L. Swedrowski, and L. Gelman, “Novel condition monitoring of induction motor bearings via motor current signature analysis,” 2017. [Online]. Available: <https://www.scopus.com/inward/record.uri?eid=2-s2.0-85029426539&partnerID=40&md5=f6c19a1122b64197aef3675fc51f46df>
- [24] M. Entezami, C. Roberts, P. Weston, E. Stewart, A. Amini, and M. Papaalias, “Perspectives on railway axle bearing condition monitoring,” *Proc. Inst. Mech. Eng. Part F J. Rail Rapid Transit*, vol. 234, no. 1, pp. 17–31, 2020, doi: 10.1177/0954409719831822.
- [25] C. M. Tarawneh, K. D. Cole, B. M. Wilson, and F. Alnaimat, “Experiments and models for the thermal response of railroad tapered-roller bearings,” *Int. J. Heat Mass Transf.*, vol. 51, no. 25–26, pp. 5794–5803, 2008, doi: 10.1016/j.ijheatmasstransfer.2008.05.011.
- [26] K. D. Cole, C. M. Tarawneh, A. A. Fuentes, B. M. Wilson, and L. Navarro, “Thermal models of railroad wheels and bearings,” *Int. J. Heat Mass Transf.*, vol. 53, no. 9–10, pp. 1636–1645, 2010, doi: 10.1016/j.ijheatmasstransfer.2010.01.031.
- [27] J. Cuanang, C. Tarawneh, M. Amaro Jr., J. Lima, and H. Foltz, “Optimization of railroad bearing health monitoring system for wireless utilization,” 2020. doi: 10.1115/JRC2020-8060.
- [28] Menteri Perhubungan Republik Indonesia, “Peraturan Menteri Perhubungan Nomor PM 60 Tahun 2012 Tentang Persyaratan Teknis Jalur Kereta Api,” 2012.
- [29] H. Suryanto, “Aplikasi Metode Elemen Hingga Untuk Analisa Struktur Statik Linier Dengan Program Msc / Nastran,” no. September, 2000, doi: 10.13140/RG.2.2.32777.95844.
- [30] J. R. Cooke and D. C. Davis, *Applied Finite Element Analysis*. New York: John Wiley & Sons, 1986.
- [31] C. R. Couch, “Comparative analysis of a heat sink using three different finite element models and validated experimentally,” *Consult. Eng. RF Microw. Components Syst.*, 2013.
- [32] I. Widiyarta, “Simulasi Perubahan Prilaku Regangan Geser Material Rel Pada Perubahan Suhu Permukaan Kontak Akibat Beban Gelinding/Gesek,” *J. Energi Dan Manufaktur*, vol. 5, no. 1, pp. 1–6, 2011.
- [33] A. Triono, “Pengaruh Kecepatan Relatif Permukaan Gesek Dan Temperatur Terhadap Koefisien Gesek Blok Rem Komposit Kereta Api,” *Rotor*, vol. 6, pp. 1–4, 2013.